

SCHEMA TIPICO 5 MW - CESSIONE TOTALE  
1500 Vdc - 800 Vac

Cabina a specifica E-Distribuzione DG2061 ed. 9 mat.200008 (Standard box Cliente)

Cabina in CAV 1 locale dim. esterne 5000x2500x2700 mm.

Cabina in CAV 2 locali (trafo + vano quadri) dim. esterne 6000x2500x2700 mm.

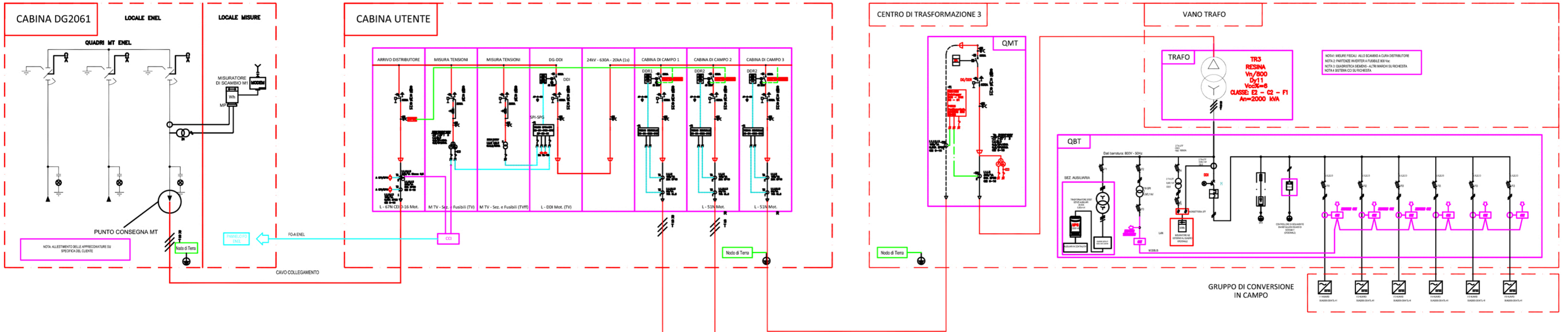

Cabina in CAV 2 locali (trafo + vano quadri) dim. esterne 6000x2500x2700 mm.

Cabina in CAV 2 locali (trafo + vano quadri) dim. esterne 6000x2500x2700 mm.

